

REVISIONS				
ECO	REV.	DESCRIPTION	DRAWN DATE	APPROVED
10250	A	REVISED OVERALL WIDTH. (WAS 51.0). ADDED POWER CABLE, MOVED CIRCUIT BREAKER, COUNTERS, DATA CONNECTORS AND ADDED ANNOTATIONS	9/21/11	CLH
10304	B	ADDED CALIBRATION REFERENCE DIMENSIONS; ADDED AXIS NOTES AND LABELS	2/1/2012	CLH
10650	C	ADDED DIMENSIONS SHOWING OVERALL HEIGHT AND LENGTH	7/25/2014	ASW

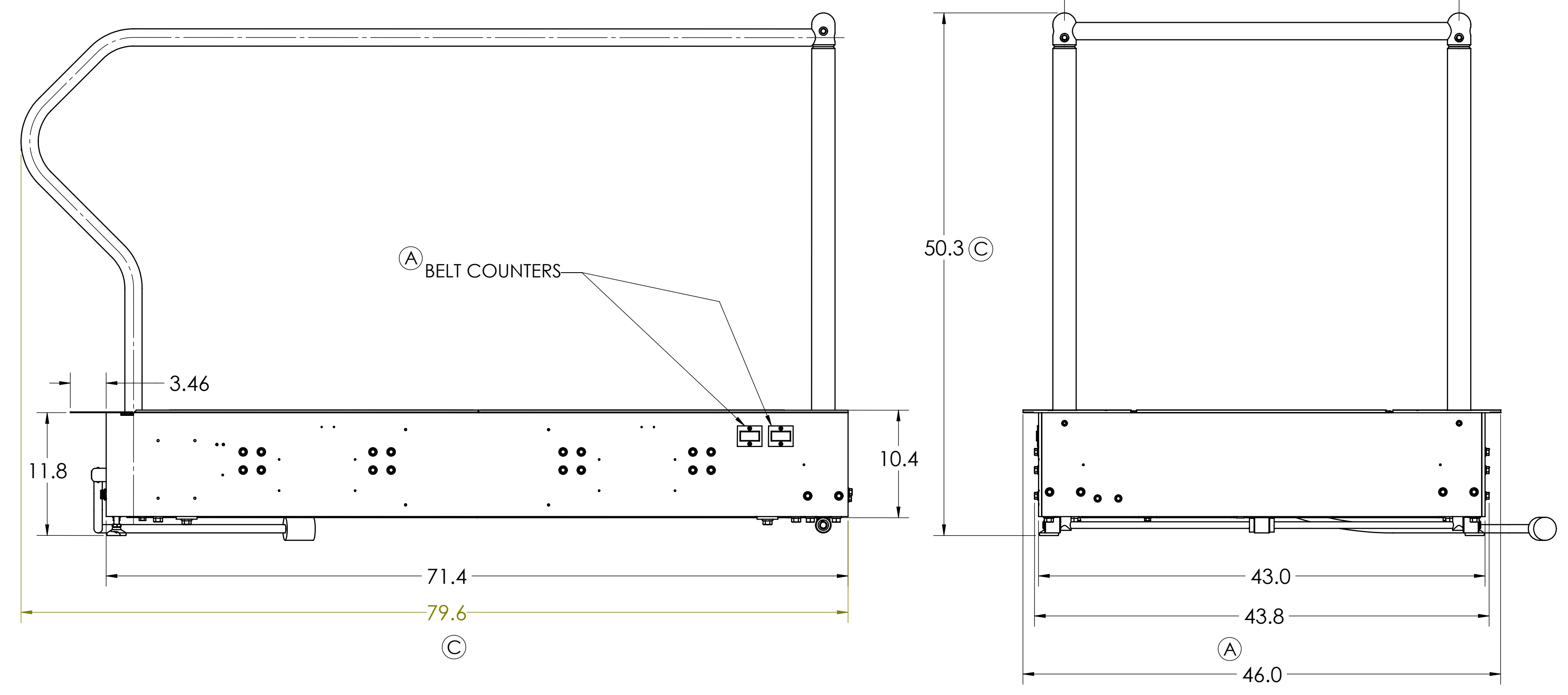
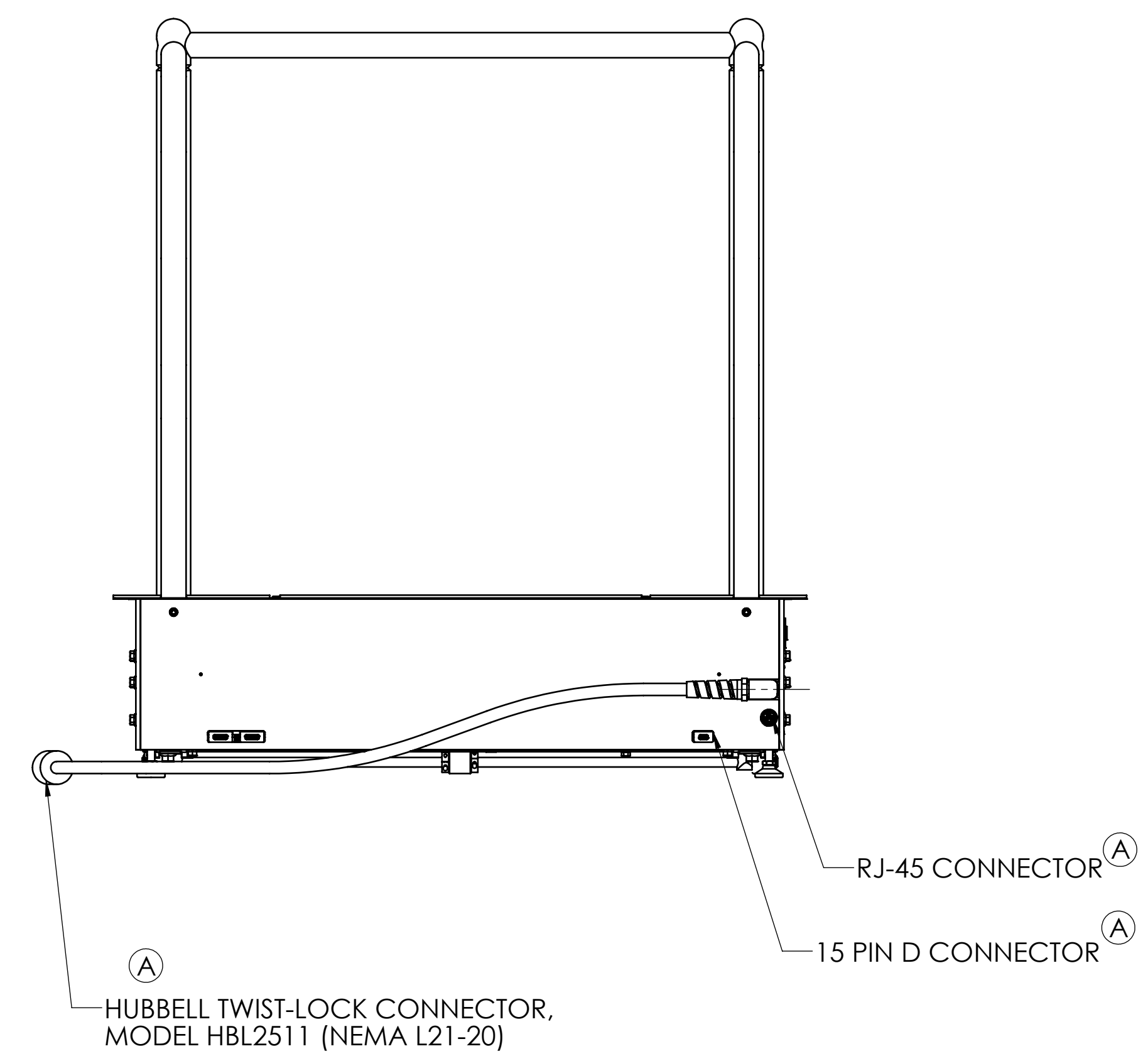
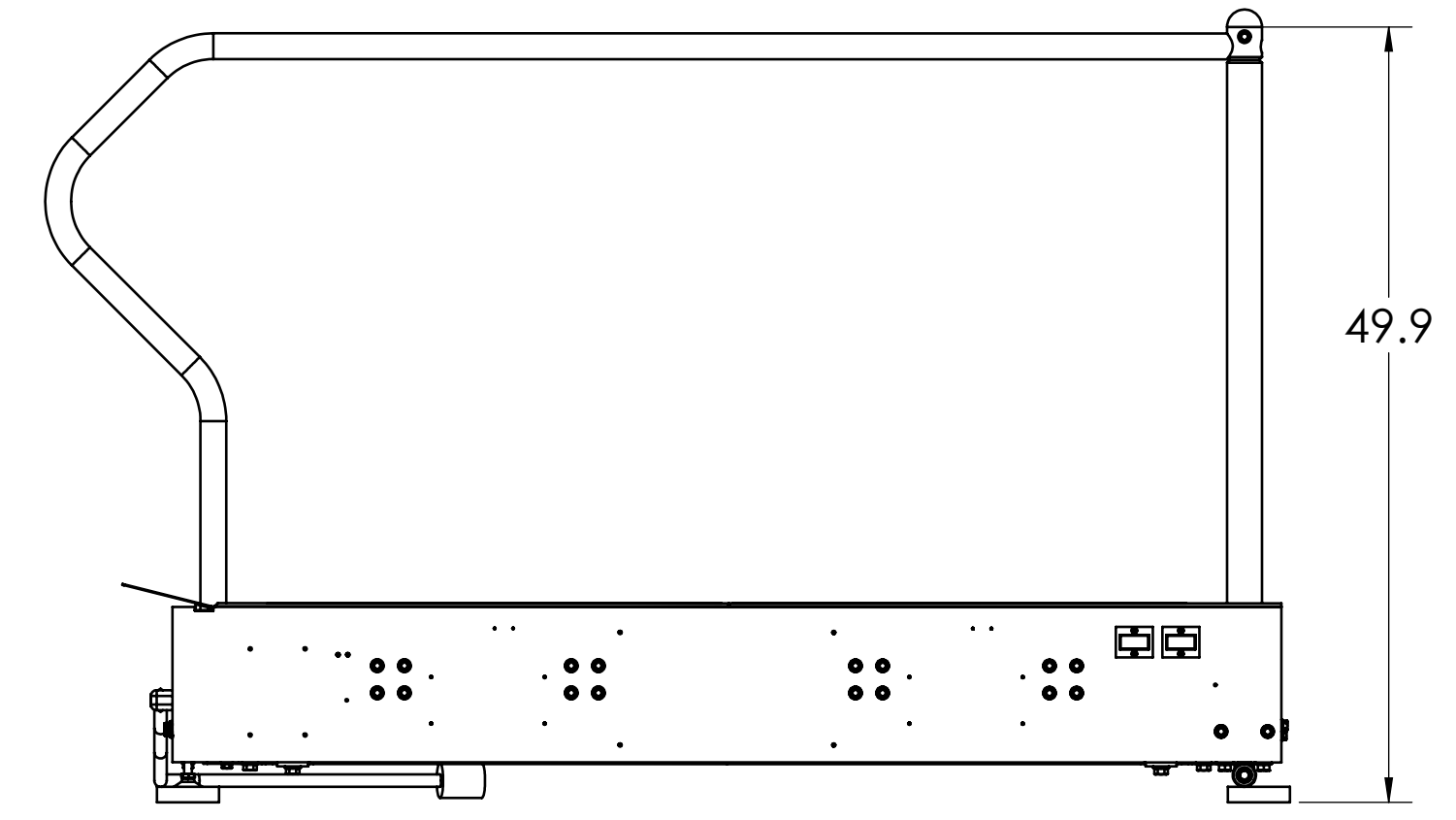
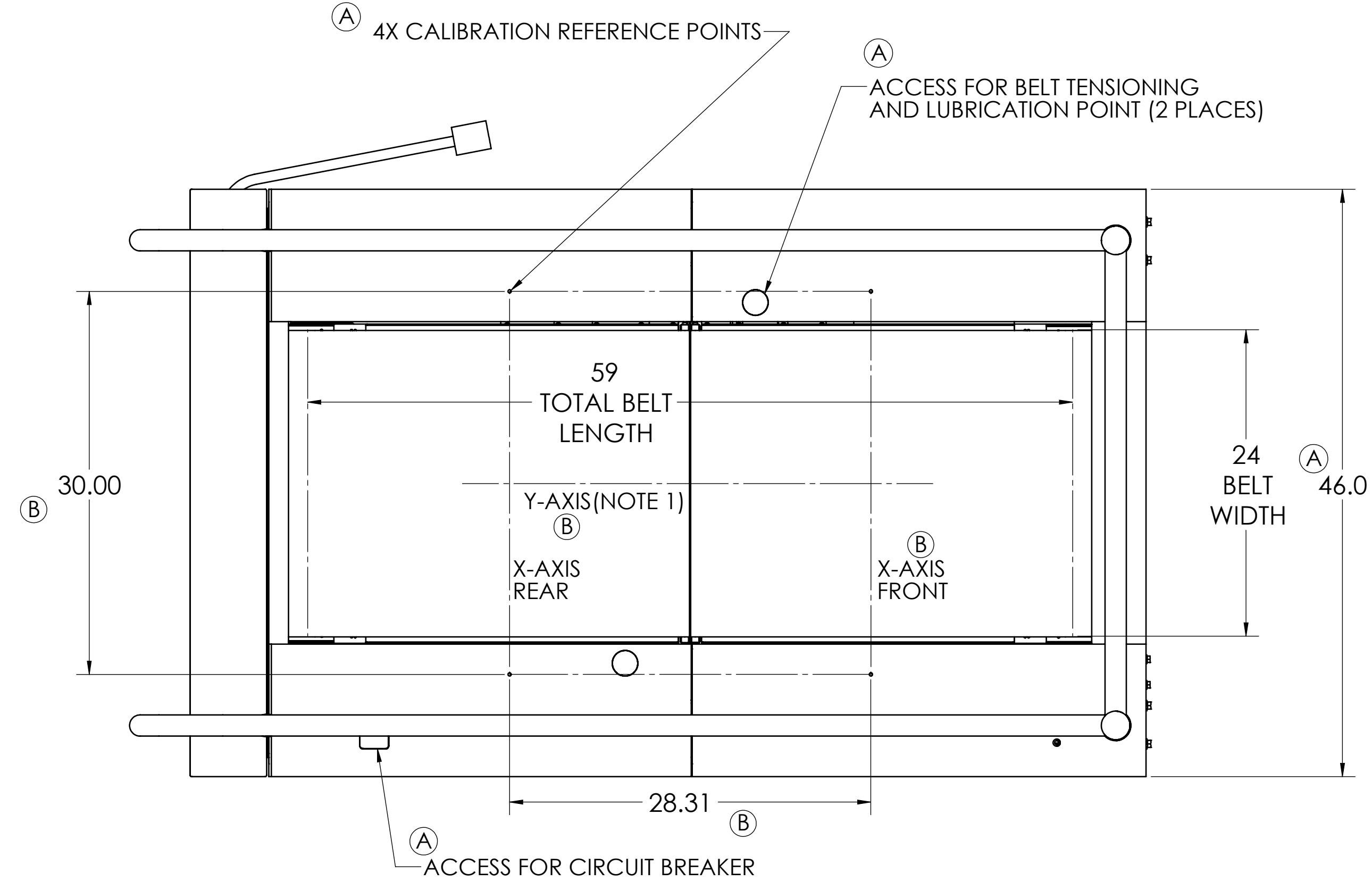
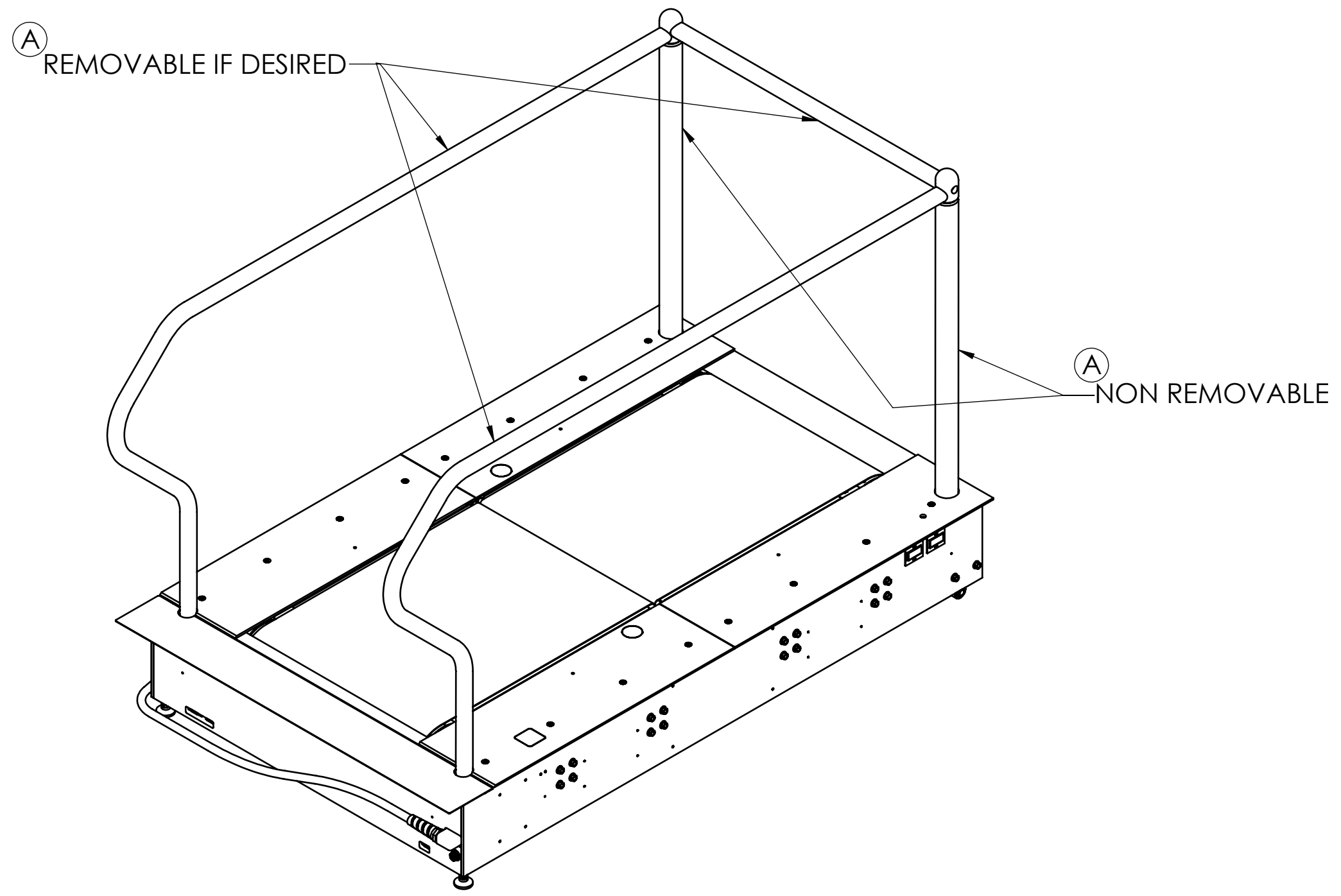

NOTES:  
1. Y-AXIS BISECTS X-AXIS LINES

PROPRIETARY AND CONFIDENTIAL  
THE INFORMATION CONTAINED IN THIS DRAWING IS THE SOLE PROPERTY OF AMTI. ANY REPRODUCTION IN PART OR AS A WHOLE WITHOUT THE WRITTEN PERMISSION OF AMTI IS PROHIBITED.

UNLESS OTHERWISE SPECIFIED:		NAME	DATE
DRAWN	PM		10/19/09
CHECKED			
ENG APPR.			
MFG APPR.			
G.A.			
COMMENTS:			

TITLE:		<b>AMTI</b>	
ASSY, TREADMILL, DBCEEWI IN FLOOR			
SIZE	DWG. NO.	REV	
D	66A-D-31594	C	
SCALE: 1:8	WEIGHT:	SHEET 1 OF 1	