

REVISIONS				
ECO	REV.	DESCRIPTION	DATE	APPROVED

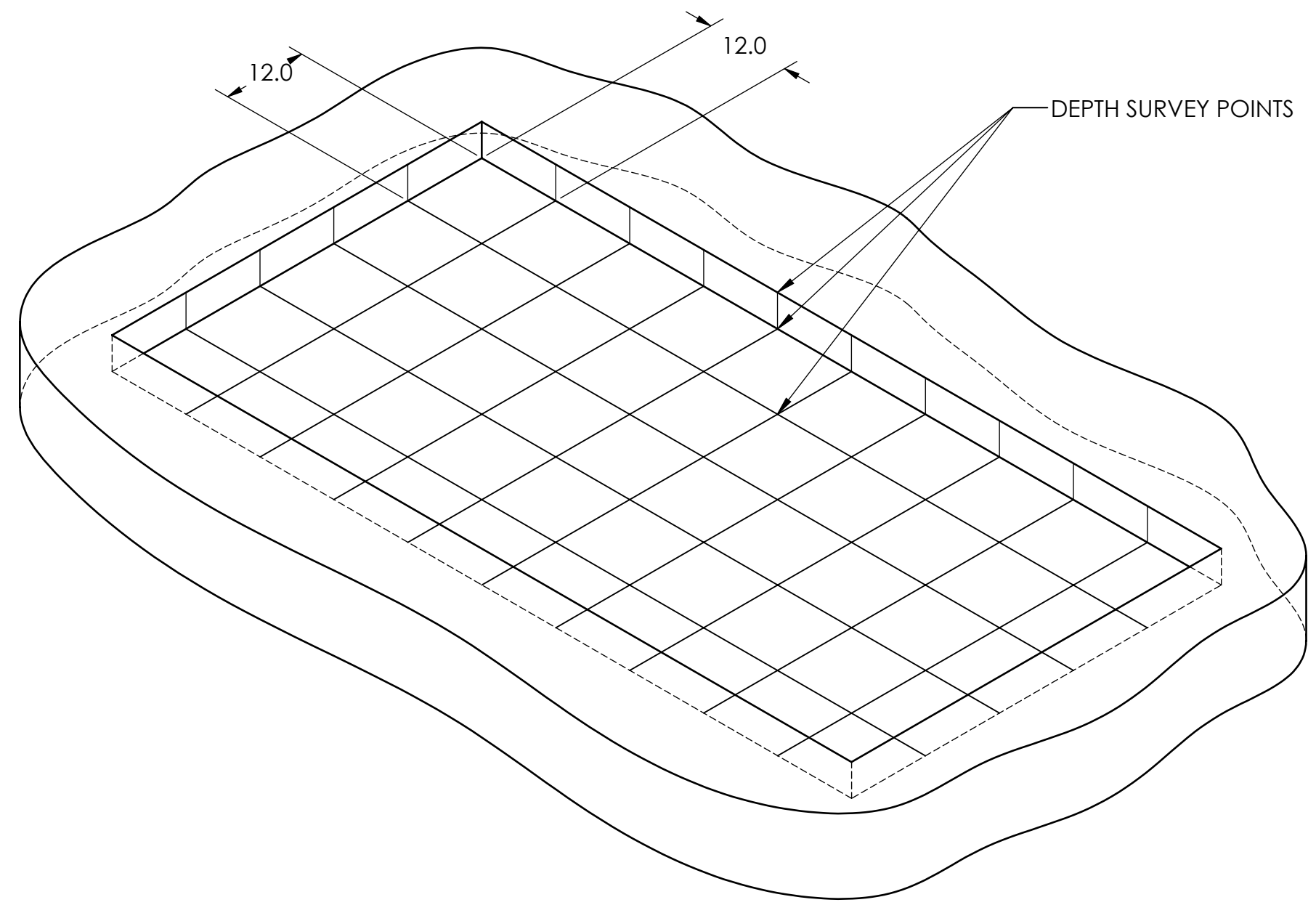

PIT DEPTH SURVEY

1. ALL MEASUREMENTS SHOULD BE REPORTED ON THE INSTALLATION QUESTIONAIR.
2. A LASER LEVEL AND TAPE MEASURE SHOULD BE SUFFICIENT TO MAKE ACCURATE MEASUREMENTS.
3. MEASURE THE PIT ON A MINIMUM 12" X 12" GRID. INCLUDE BOTH POINTS IN THE BOTTOM OF THE PIT, AND AT THE TOP PERIMETER.
4. MEASUREMENTS SHOULD Be REPORTED TO THE NEAREST 1/16".

PROPRIETARY AND CONFIDENTIAL
 THE INFORMATION CONTAINED IN THIS DRAWING IS THE SOLE PROPERTY OF AMTI. ANY REPRODUCTION IN PART OR AS A WHOLE WITHOUT THE WRITTEN PERMISSION OF AMTI IS PROHIBITED.

AMTI		
TITLE: FORCE PLATE PIT DEPTH SURVEY		
SIZE B	DWG. NO.	REV --
SCALE: 1:16	WEIGHT:	SHEET 1 OF 1