

FPSTAIRS

DESCRIPTION
 FPSTAIRS CONSIST OF 2 SEPARATE BUT INTERLACED STAIR STRUCTURES. THEY ARE SHIPPED PRE-ASSEMBLED AND INTERLACED, AND MUST BE MOVED TOGETHER. WHEELS AT THE REAR END OF 2ND STAIR STRUCTURE ARE INTENDED TO AID IN MOVING AND POSITIONING THE STAIRS.

INSTALLATION
 EACH STAIR STRUCTURE IS MOUNTED TO ITS OWN FORCE PLATE. TO COMPLETE FPSTAIRS INSTALLATION POSITION EACH STAIR STRUCTURE SO THAT THE HAND SCREWS ARE OVER THE HOLES IN THE FORCE PLATES AND LIGHTLY TIGHTEN. ALIGN SIDES FACES OF STAIR TREADS AND ADJUST THE POSITION OF THE 2 STRUCTURES SO THAT THE GAPS BETWEEN STAIR RISERS AND ADJACENT STAIR TREADS ARE COMPARABLE. TIGHTEN THE HAND SCREWS.

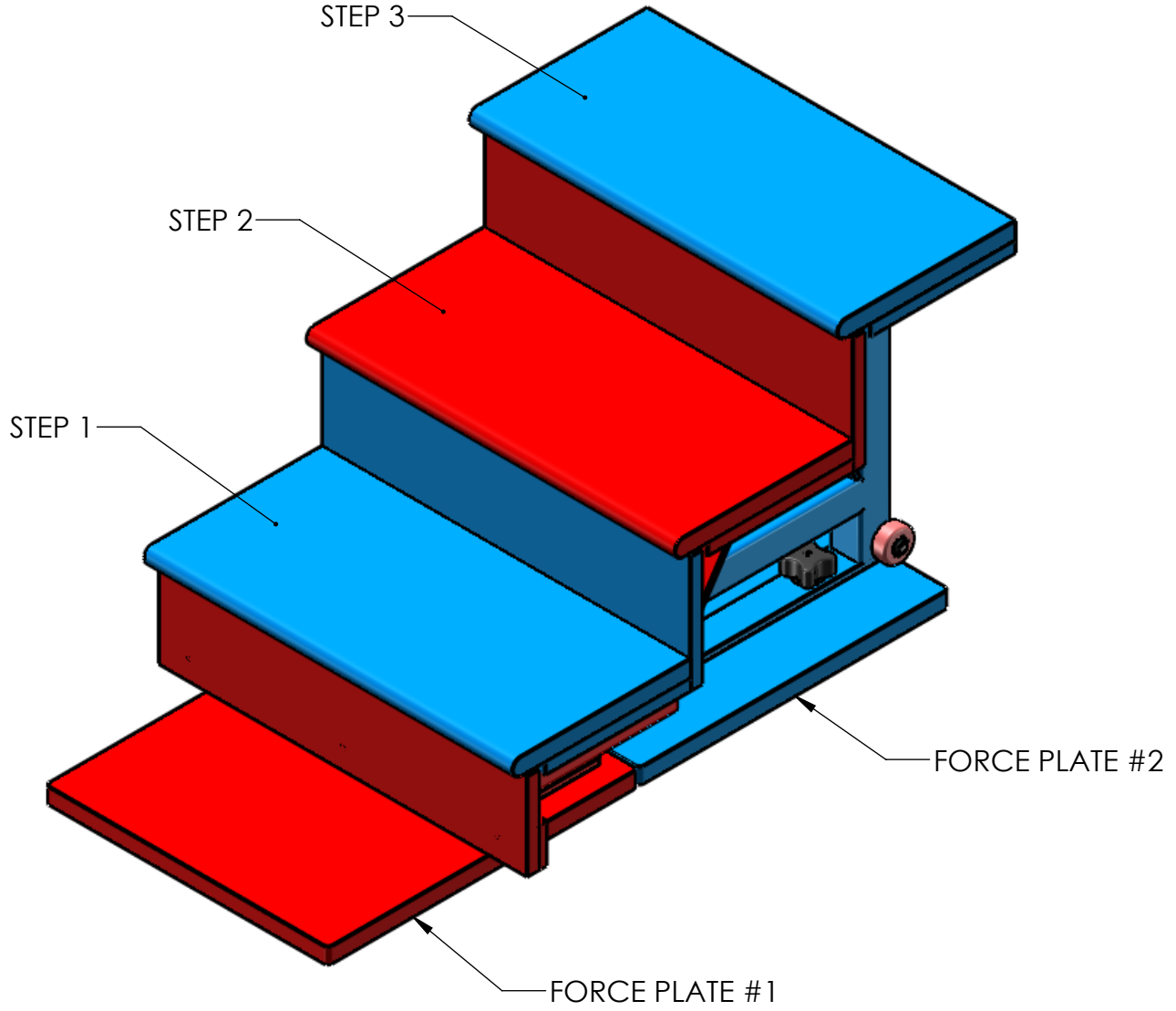

STEP 1 REGISTERS ON FORCE PLATE 2
 STEP 2 REGISTERS ON FORCE PLATE 1
 STEP 3 REGISTERS ON FORCE PLATE 2

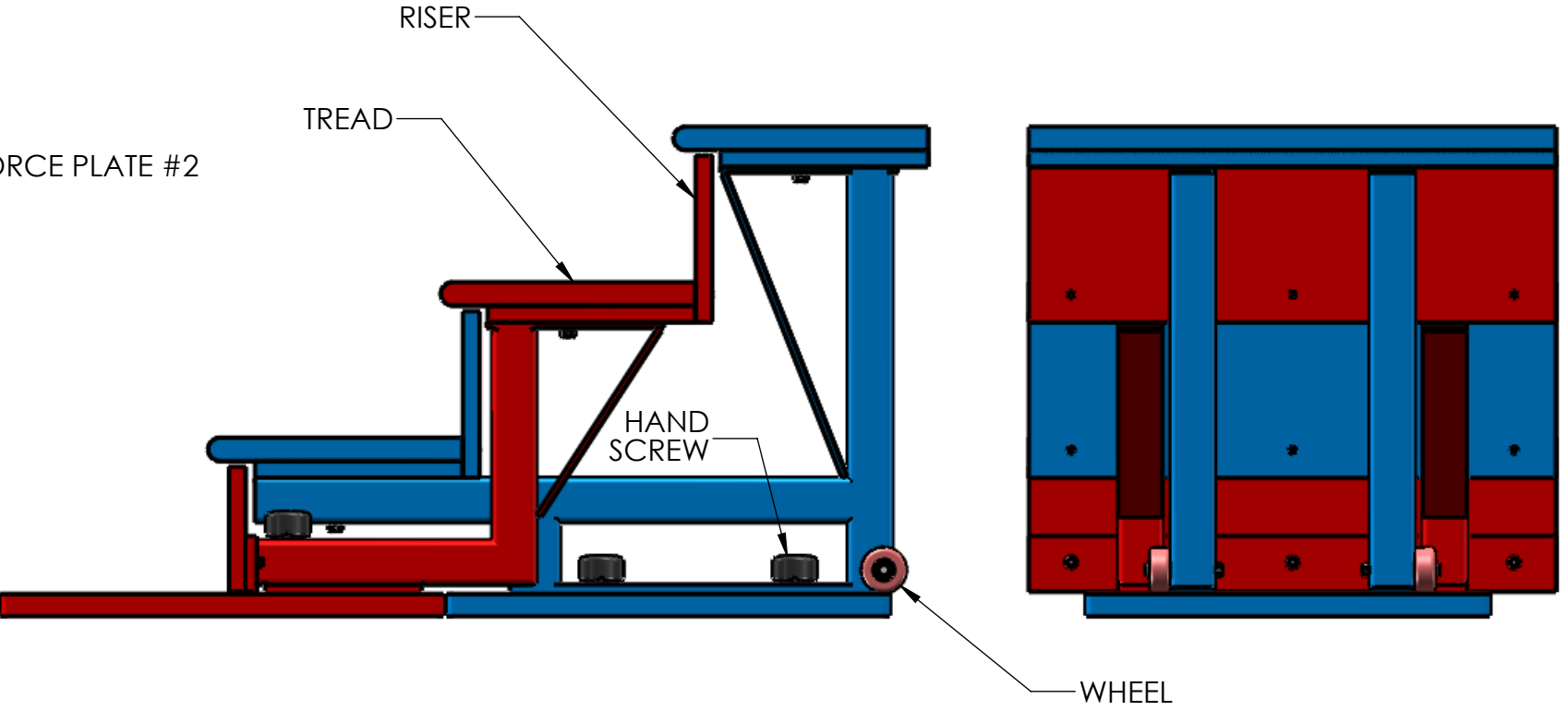

PROPRIETARY AND CONFIDENTIAL
 THE INFORMATION CONTAINED IN THIS DRAWING IS THE SOLE PROPERTY OF AMTI. ANY REPRODUCTION IN PART OR AS A WHOLE WITHOUT THE WRITTEN PERMISSION OF AMTI IS PROHIBITED.

UNLESS OTHERWISE SPECIFIED:		NAME	DATE	AMTI	
DIMENSIONS ARE IN INCHES		DRAWN	CLH		9/27/13
TOLERANCES:		CHECKED			
DECIMALS	ANGLES	ENG APPR.	CLH		10/02/13
.X ± .030	±1/2°	MFG APPR.			
.XX ± .015		Q.A.			
.XXX ± .005		COMMENTS:			
FRACTIONAL ± 1/32					
INTERPRET GEOMETRIC TOLERANCING PER:					
MATERIAL	--				
FINISH	--				
DO NOT SCALE DRAWING					
SIZE	DWG. NO.	REV			
B	24N-34962	--			
SCALE: 3:16	WEIGHT:	SHEET 1 OF 2			

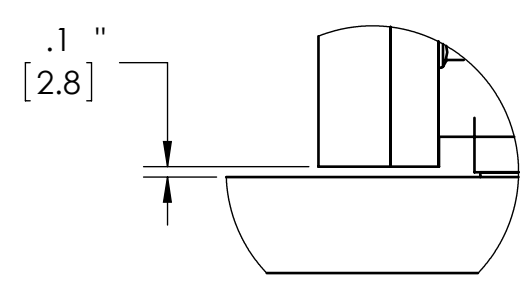
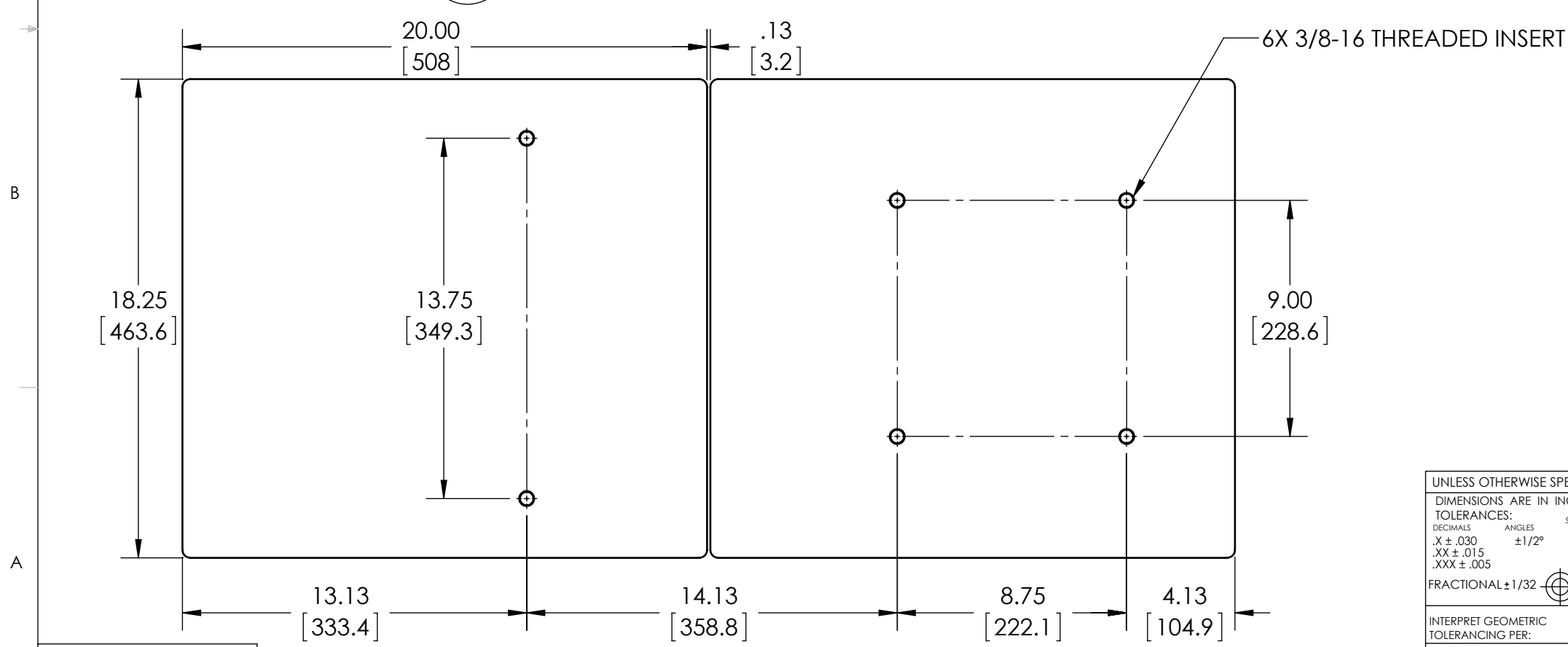
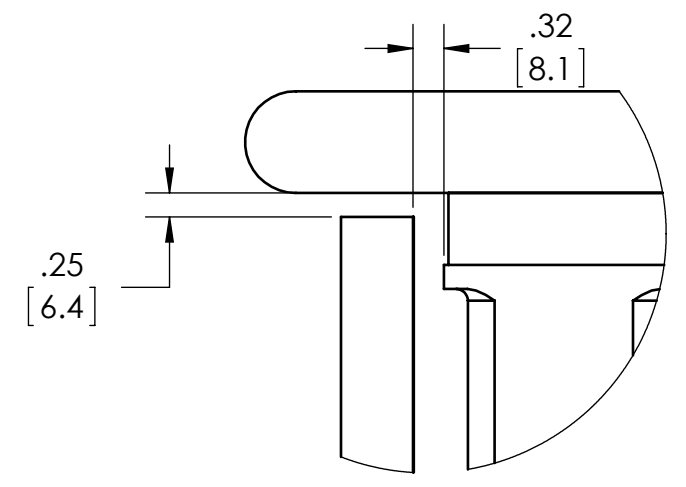
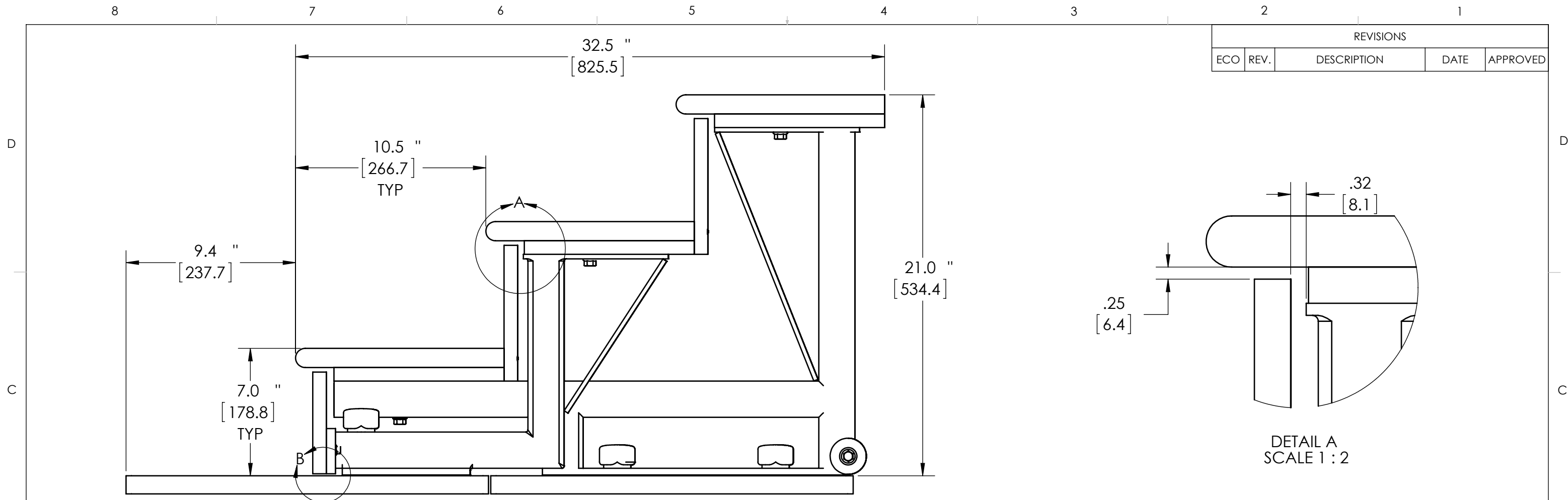

PROPRIETARY AND CONFIDENTIAL
 THE INFORMATION CONTAINED IN THIS DRAWING IS THE SOLE PROPERTY OF AMTI. ANY REPRODUCTION IN PART OR AS A WHOLE WITHOUT THE WRITTEN PERMISSION OF AMTI IS PROHIBITED.

UNLESS OTHERWISE SPECIFIED:		NAME	DATE	AMTI FPSTAIRS OR6 ASSEMBLY	
DIMENSIONS ARE IN INCHES		DRAWN	CLH		9/27/13
TOLERANCES:		CHECKED			
DECIMALS .X ± .030 ANGLES ±1/2° SURFACE FINISH 63 FRACTIONAL ±1/32		ENG APPR.	CLH		10/02/13
INTERPRET GEOMETRIC TOLERANCING PER:		MFG APPR.			
MATERIAL		Q.A.			
FINISH		COMMENTS:			
DO NOT SCALE DRAWING					
SIZE	DWG. NO.	REV			
B	24N-34962	--			
SCALE: 3:16	WEIGHT:	SHEET 2 OF 2			